

The Stone Nut of the Yorktown Windmill

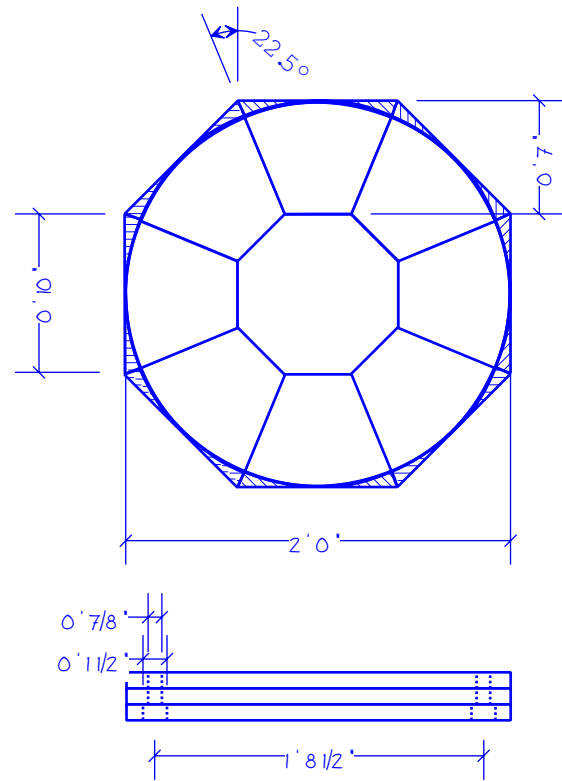

Detail of Stone Nut Plate

The top and bottom plates of the Stone Nuts consist of three layers of 1 inch white oak. Each lamination is constructed from 8 'pie slices' cut at 22.5 degrees and joined with biscuits and glue.

Each lamination is rotated by 22.5 degrees from the adjacent plate to ensure that the joints are not aligned. This provides strength and increased integrity to the entire assembly and avoid significant misalignments of the grain that might produce 'cross-grain conflicts.'

Laminated Stone Nut Plate

The mortises that will receive the teeth penetrate through the plates and are two-part. The lower mortise is 1-1/2" in diameter and has a depth equal to the thickness of the innermost plate (1"). The second part of the mortise is 7/8" and penetrates through the remaining two laminations.

The centers of opposing mortises are 20-1/2" apart.

Placement of Screws and Tooth Mortises in Stone Nut Plate

Two inch screws are installed through the plate laminations to provide additional reinforcement in the event of adhesive failure. Exterior #8 screws are used and three are installed (from the top-side only) for each plate segment.

The screws are installed in 3/8" pre-drilled sockets and are capped with 3/8" oak bungs. Installation of the screws is consistent with the diagram and placement should not conflict with the tooth mortises.

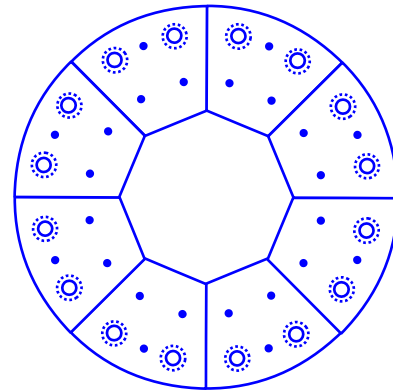

Placement of Clasp Arm Assembly on Stone Nut Plate

Three inch thick clasp arm assemblies are installed on each side of the stone nut to facilitate connection to the stone drive shaft.

The clasp arms should be attached in a manner consistent with the diagram in order to minimize problems that could result from cross-grain connections.

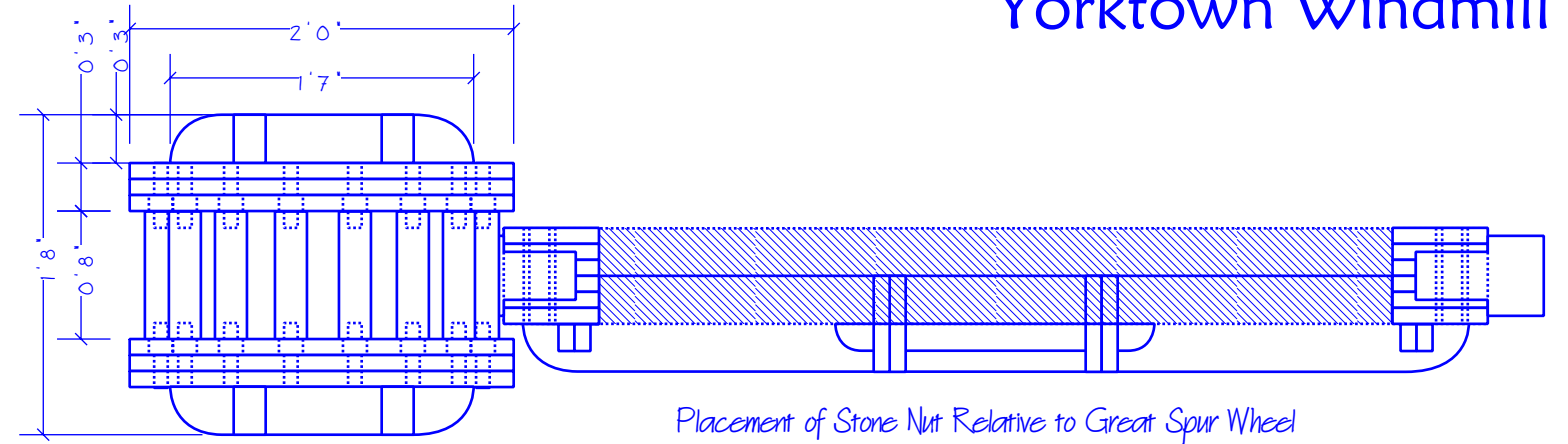
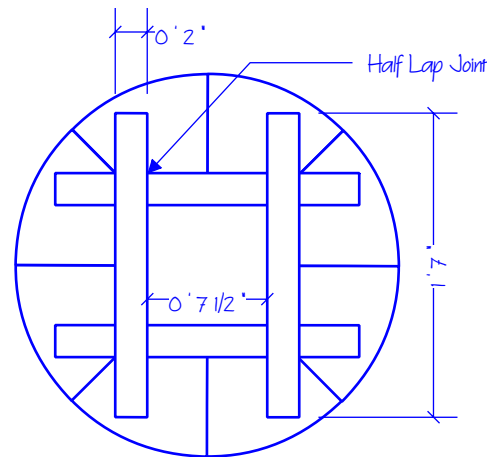

Placement of Stone Nut Relative to Great Spur Wheel

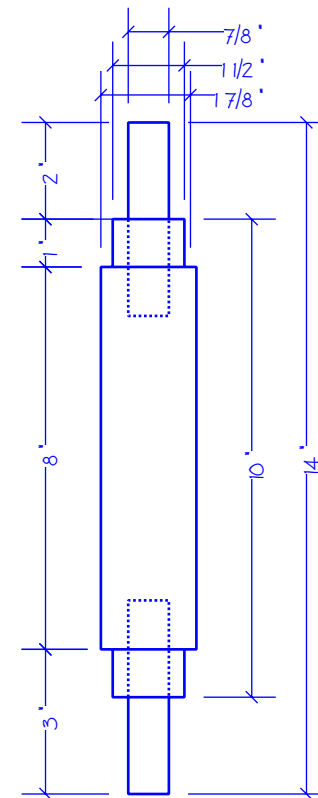

Detail of Tooth (Alt Scale: 1:4)

The tooth of the stone nut is cylindrical and is seated in a mortise that is cut in the top and bottom plate. In the case of these teeth, the primary cylinder is cut from a single, 10" piece of ash and is joined by a 7/8" dowel that is inserted from the top and bottom. The dowel is glued into both the tooth and the plate.

The reason a dowel is used rather than simply turning the tooth to 7/8" and the insertion point is two fold.

- 1) To eliminate the wood loss that is required to reduce a 2" dowel to 7/8".
- 2) To ensure that the tightest possible fit of the tooth into the glue joint.

SCALE 1" = 1'-0" (1:12)

